

LHSA SERIES - ELBOW / STUDDED / L-BALL ROD END BALL JOINTS

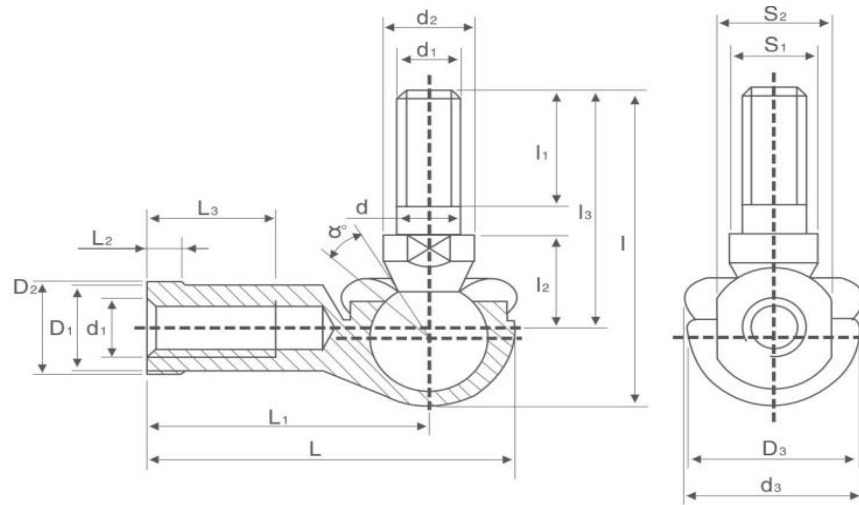

OUR PART NUMBER	ALTERNATIVE REFERENCE	d	d ₁	d ₂	d ₃	l	l ₁	l ₂	l ₃	S ₁	L	L ₁	L ₂	L ₃	D ₁	D ₂	D ₃	S ₂	α	Load Rating (kN)	Weight (g)
LHSA5	SQ5-RS	5	M5X0.8	9	19	29	8	10	21	7	35	27	4	14	9	11	16	9	25	2.2	26
LHSA5L	SQL5-RS	5	M5X0.8	9	19	29	8	10	21	7	35	27	4	14	9	11	16	9	25	2.2	26
LHSA6	SQ6-RS	6	M6X1.0	10	20	35.5	11	11	26	8	40	30	5	14	10	13	19	11	25	3.5	39
LHSA6L	SQL6-RS	6	M6X1.0	10	20	35.5	11	11	26	8	40	30	5	14	10	13	19	11	25	3.5	39
LHSA8	SQ8-RS	8	M8X1.25	12	24	42.5	12	14	31	10	48	36	5	17	12.5	16	23	14	25	6.6	68
LHSA8L	SQL8-RS	8	M8X1.25	12	24	42.5	12	14	31	10	48	36	5	17	12.5	16	23	14	25	6.6	68
LHSA10	SQ10-RS	10	M10X1.25	14	30	50.5	15	17	37	11	57	43	6.5	21	15	19	27	17	25	10	112
LHSA10L	SQL10-RS	10	M10X1.25	14	30	50.5	15	17	37	11	57	43	6.5	21	15	19	27	17	25	10	112
LHSA12	SQ12-RS-1	12	M12X1.75	17	32	64.5	24	19	49	15	66	50	6.5	25	17.5	22	31	19	25	16	164
LHSA12L	SQL12-RS-1	12	M12X1.75	17	32	64.5	24	19	49	15	66	50	6.5	25	17.5	22	31	19	25	16	164
LHSA14	SQ14-RS-1	14	M14X2.0	19	38	79.5	28	21.5	56	17	75	57	8	26	20	25	35	22	25	19	254
LHSA14L	SQL14-RS-1	14	M14X2.0	19	38	79.5	28	21.5	56	17	75	57	8	26	20	25	35	22	25	19	254

Studded male-female ball joint/track rod ends with rubber boot are available both in Right Hand and Left Hand Designs (Suffixed L). They are also commonly known as L-Ball Rod ends with covers, or Elbow Rod Ends and often used in both Industrial and Automotive applications